

# + Quick Guide

## EE600 - Differential Pressure Sensor



your partner  
in sensor  
technology.

### **i** PLEASE NOTE

Find this document and further product information on our website at [www.epluse.com/ee600](http://www.epluse.com/ee600).

## Electrical Connection

### **⚠** WARNING

Incorrect installation, wiring or power supply may cause overheating and therefore personal injuries or damage to property. It is essential that the cables are not under voltage during installation. No voltage must be applied when the product is connected or disconnected. For correct cabling of the device, always observe the presented wiring diagram for the product version used.

The manufacturer cannot be held responsible for personal injuries or damage to property as a result of incorrect handling, installation, wiring, power supply and maintenance of the device.

### Analogue Output

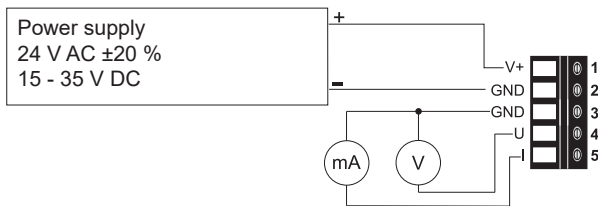

### Digital Output

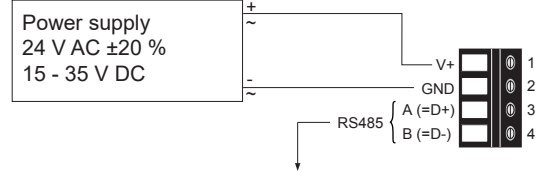

## Installation

### Pressure Connection

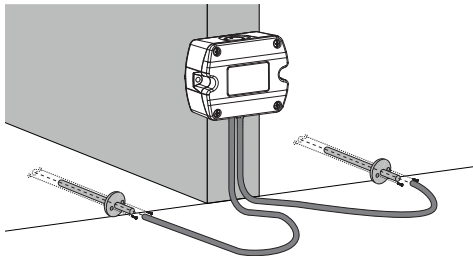

Use a  $\varnothing 7.5$  mm drill for installing the pressure connection nipples into the duct.

### Mounting Examples

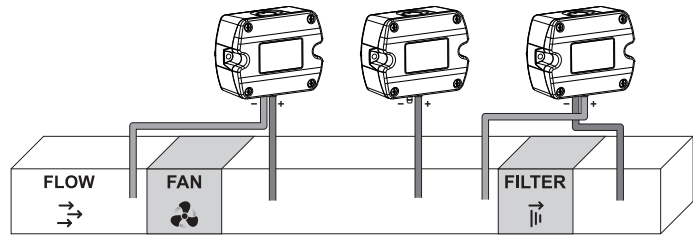

## User Interface - LED Indication

### Green LED

Flashing (1 s interval)	EE600 operates normally, the measured data is within the selected measuring range
One flash (2 s)	Confirms adjustment or return to factory settings
Off	No power supply or electronics failure
Fast flashing (0.2 s interval)	Auto-zero is executed, first time 10 s after start/reset

### Red LED

Flashing (1 s interval)	The measured data is out of the selected range (overload or reversed pressure connection)
One flash (2 s)	Indicates the failure of the attempt to adjust zero point or span point, or to return to factory adjustment

## EE600 with Analogue Output

S1	S2	MR <sup>1)</sup>	S3	S4	Time	S5	S6	Unit	S7	DPB <sup>2)</sup>	S8	Output	S9	Setting <sup>3)</sup>
0	0	100 %	0	0	50 ms	0	0	Pa	0	on	0	0 - 10 V / 4 - 20 mA	0	DIP switches
1	0	75 %	1	0	500 ms	1	0	mbar	1	off	1	0 - 5 V / 0 - 20 mA	1	PCS10
0	1	50 %	0	1	2 s	0	1	inch WC						
1	1	25 %	1	1	4 s	1	1	kPa						

1) Measuring range 2) Display backlight 3) These and further settings can be changed with PCS10 via USB configuration adapter (HA011066) while DIP switch S9 = 1. Only available with version with 10 DIP switches.

### E+E Elektronik Ges.m.b.H.

Langwiesen 7  
4209 Engerwitzdorf | Austria  
T +43 7235 605-0  
F +43 7235 605-8  
info@epluse.com  
www.epluse.com



# EE600 with RS485 Interface Electronics Board Layout

The bus termination shall be realized with the 120 Ω resistor (slide switch on board).

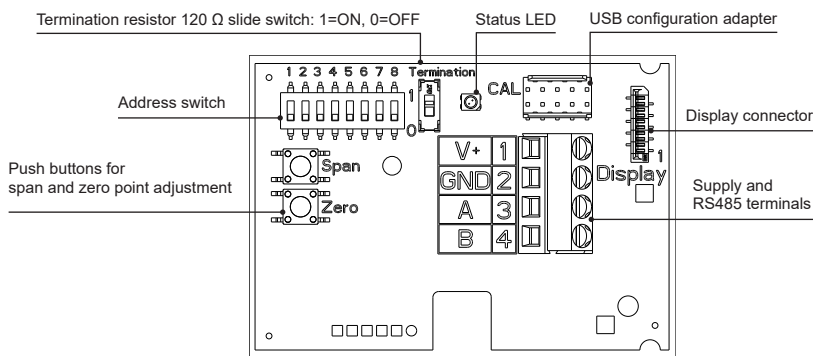

## Address Setting

Address Switch	Option
	<p><b>Address setting via PCS10 Product Configuration Software (= factory setting)</b>                      All DIP switches at position 0 → factory-set default address (43<sub>DEC</sub>, 0x2B) applicable, can be changed via software (PCS10 or Modbus protocol, permitted values: 1...247).                      Example: Address is set via configuration software.</p>
	<p><b>Address setting via DIP switches</b>                      DIP switches in any other position than 0 indicate the effective Modbus address which overrules the factory setting and any Modbus address set via PCS10 or Modbus command (permitted values: 1...247).                      Example: Address set to 11<sub>DEC</sub> (0000 1011<sub>BIN</sub>).</p>

## Communication Settings

	Modbus	
	Factory settings	User selectable values (via PCS10)
Baud rate	As specified in the order code	9600, 19200, 38400, 57600, 76800, 115200
Data bits	8	8
Parity	Even	None, odd, even
Stop bits	1	1, 2
Modbus address	43	1...247

## Modbus Protocol

The recommended settings for multiple devices in a Modbus RTU network are 9600, 8, even, 1.

Address, Baud rate, parity and stop bits can be set via:

- PCS10, Product Configuration Software and the USB configuration adapter HA011066.
- Modbus protocol in the register 1 (0x00) and 2 (0x01).

Refer to Application Note Modbus AN0103 (available on [www.epluse.com/ee600](http://www.epluse.com/ee600)).

The measured values are saved as 32 bit floating point value and as 16 bit signed integer value, see Modbus register map below.

## Modbus Register Map

Parameter	Unit	FLOAT 32			INT16	
		Register number <sup>1)</sup> [DEC]	Register address <sup>2)</sup> [HEX]	Scale <sup>3)</sup>	Register number <sup>1)</sup> [DEC]	Register address <sup>2)</sup> [HEX]
Read register: function code 0x03 / 0x04						
Differential pressure	mm H <sub>2</sub> O	1211	4BA	10	4106	1009
Differential pressure	mbar	1213	4BC	100	4107	100A
Differential pressure	Pa	1215	4BE	1	4108	100B
Differential pressure	kPa	1217	4C0	1000	4109	100C
Differential pressure	inch WC	1219	4C2	100	4110	100D
Air velocity	m/s	1041	410	100	4021	FB4
Air velocity	ft/min	1043	412	1	4022	FB5
Volume flow	m <sup>3</sup> /h	1055	41E	1	4028	FBB
Volume flow	l/s	1057	420	1	4029	FBC
Volume flow	m <sup>3</sup> /s	1059	422	1000	4030	FBD
Volume flow	ft <sup>3</sup> /min	1181	49C	1	4091	FFA
Filter monitoring	%	1075	432	10	4038	FC5
Level indicator	cm	1077	434	10	4039	FC6
Level indicator	inch	1079	436	10	4040	FC7

1) Register number starts from 1

2) Register address starts from 0

3) 1xx is scale. E.g. for 1:100, reading of 2550 is equivalent to 25.5